

**LPMS**  
USA

Low Pressure Molding  
Solutions from Design  
to Production



## BETA 370

Horizontal injection shuttle table

- ◆ Horizontal-injection system with a single injection gun
- ◆ Compact design with integrated melt tank
- ◆ 7.5" touchscreen plc with multi-language capabilities
- ◆ Two thermal zones for precise melt control
- ◆ Equipped with programmable ejection system
- ◆ Equipped with a safety-light curtain and photoelectric actuators for operator safety
- ◆ Shuttle table design; one upper mold serves two bottom molds which increases throughput

## Dimensions

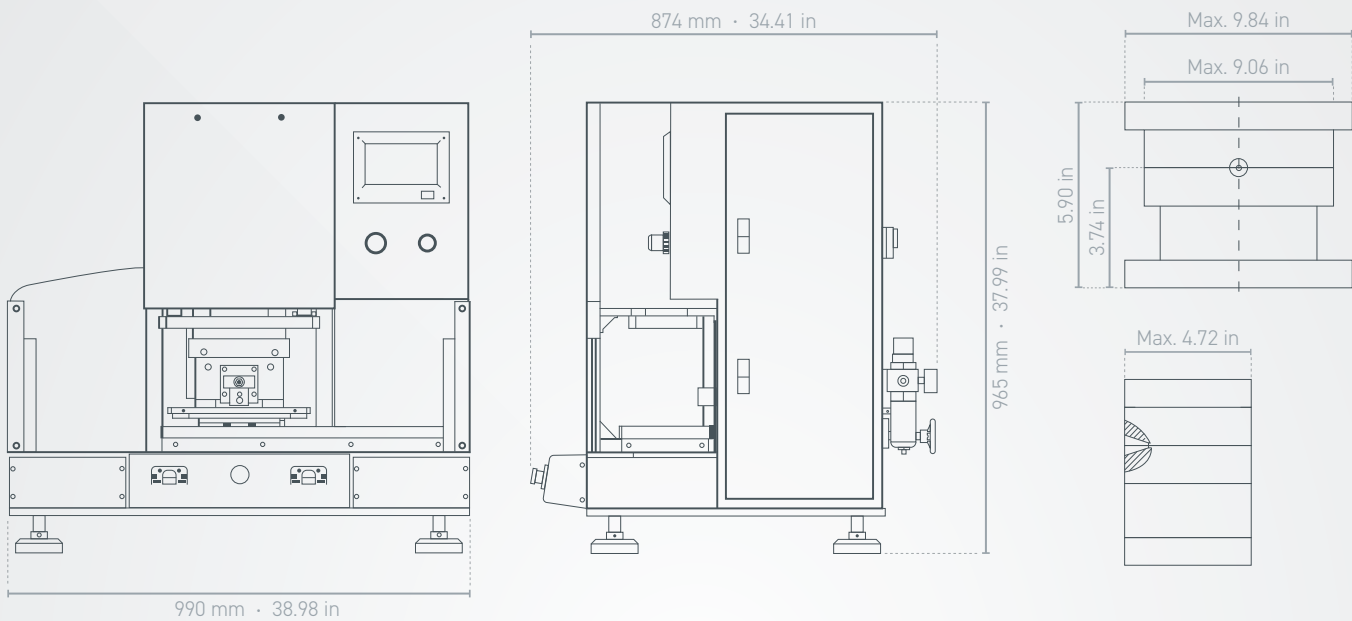

Machine

Mold Set

## Specifications

<b>Machine Size</b>	990 × 874 × 965 mm · 38.98 × 34.41 × 37.99 in · 881 lbs
<b>Electricity</b>	200-240 VAC · 1 Phase · 50 Hz · 25 A
<b>Air Input</b>	30-100 psi
<b>Air Required</b>	> 100 psi
<b>Clamping Method</b>	Pneumatic
<b>Clamping Force</b>	2 Tons
<b>Clamping Stroke</b>	75 mm
<b>Max. Mold Size</b>	250 × 130 × 75 mm
<b>Platen Size</b>	250 × 130 mm
<b>Nozzle</b>	LPMS-G02
<b>Safety Features</b>	Light curtain · photo-electric buttons · E-stop button
<b>Melt Tank Quantity / Volume</b>	One integrated · 7L
<b>Temperature Control Zones</b>	2